



BOOM BOX FX2



User Manual

©2020 ADJ Products, LLC all rights reserved. Information, specifications, diagrams, images, and instructions herein are subject to change without notice. ADJ Products, LLC logo and identifying product names and numbers herein are trademarks of ADJ Products, LLC. Copyright protection claimed includes all forms and matters of copyrightable materials and information now allowed by statutory or judicial law or hereinafter granted. Product names used in this document may be trademarks or registered trademarks of their respective companies and are hereby acknowledged. All non-ADJ Products, LLC brands and product names are trademarks or registered trademarks of their respective companies.

ADJ Products, LLC and all affiliated companies hereby dis-claim any and all liabilities for property, equipment, building, and electrical damages, injuries to any persons, and direct or indirect economic loss associated with the use or reliance of any information contained within this document, and/or as a result of the improper, unsafe, insufficient and negligent as-sembly, installation, rigging, and operation of this product.

Europe Energy Saving Notice

Energy Saving Matters (EuP 2009/125/EC)

Saving electric energy is a key to help protecting the environment. Please turn off all electrical products when they are not in use. To avoid power consumption in idle mode, disconnect all electrical equipment from power when not in use. Thank you!

Unpacking: Thank you for purchasing the Boom Box FX2 by ADJ Products, LLC. Every Boom Box FX2 has been thoroughly tested and has been shipped in perfect operating condition. Carefully check the shipping carton for damage that may have occurred during shipping. If the carton appears to be damaged, carefully inspect your fixture for any damage and be sure all equipment necessary to operate the unit has arrived intact. In the event damage has been found or parts are missing, please contact our toll free customer support number for further instructions. Please do not return this unit to your dealer without contacting customer support first.

Introduction: The Boom Box FX2 is a DMX intelligent LED moon-flower, strobe, & laser fixture. The Boom Box FX2 has 2 DMX channel modes, a 3 channel mode and 19 channel mode. The fixture can operate in as a stand alone fixture or in a Master/Slave set up. The Boom Box FX2 has three operating modes; sound active, show mode, and DMX Control. For best results use fog or special effects smoke to enhance the beams projections.

Customer Support: ADJ Products, LLC provides a toll free customer support line, to provide help and to answer any question should you encounter problems during your set up or initial operation. You may also visit us on the web at www.adj.com for any comments or suggestions. Service Hours are Monday through Friday 8:00 a.m. to 4:30 p.m. Pacific Standard Time.

Voice: (800) 322-6337
Fax: (323) 582-2941
E-mail: support@adj.com

Warning! To prevent or reduce the risk of electrical shock or fire, do not expose this unit to rain or moisture.

Caution! This may cause eye damage. Avoid looking directly into the light source. Use sensible precaution.

To optimize the performance of this product, please read these operating instructions carefully to familiarize yourself with the basic operations of this unit. These instructions contain important safety information regarding the use and maintenance of this unit. Please keep this manual with the unit, for future reference.

Boom Box FX2**Features**

- 2 DMX Channel Mode's: 3 Channel and 19 Channel
- 3 Operating Modes - Sound Active, Show Mode, & DMX Control
- 8 Different Gobos
- RGBWA LED's
- Green & Red Lasers
- Internal Microphone
- Digital Display for Address and Function Setting
- Power Cord Daisy Chain
- UC IR Compatible (Not Included) & Airstream IR Compatible (transmitter not included)

Boom Box FX2**Warranty Registration**

The Boom Box FX2 carries a 1 Year limited warranty. Please fill out the enclosed warranty card to validate your purchase and warranty. You may also register your product online at www.americandj.com. All returned service items whether under warranty or not, must be freight pre-paid and accompany a return authorization (R.A.) number. If the unit is under warranty you must provide a copy of your proof of purchase invoice. Please contact ADJ customer support for a R.A. number.

Boom Box FX2**Handling Precautions**

Caution! There are no user serviceable parts inside this unit. Do not attempt any repairs yourself, doing so will void your manufactures warranty. In the unlikely event your unit may require service please contact ADJ Products, LLC.

During operation the housing may become extremely hot. Avoid touch-ing the unit with bare hands while in use.

ADJ Products, LLC will not accept any liability for any resulting dam-ages caused by the non-observance of this manual or any unauthor-ized modification to this unit.



Safety Issues: This unit may “pop” the fuse if the maximum allotted load of 2 amps is reached.

- To reduce the risk of electrical shock or fire, do not expose this unit rain or moisture.
- Do not spill water or other liquids into or on to your unit.
- Do not attempt to remove or break off the ground prong from the electrical cord. This prong is used to reduce the risk of electrical shock and fire in case of an internal short. Do not attempt to operate this unit if the power cord has been frayed or broken.
- Disconnect from main power before making any type of connection.
- Do not remove the cover under any conditions. There are no user serviceable parts inside.
- Always be sure to mount this unit in an area that will allow proper ventilation. Allow about 6” (15cm) between this device and a wall.
- Do not attempt to operate this unit, if it becomes damaged.
- This unit is intended for indoor use only, use of this product outdoors voids all warranties.
- During long periods of non-use, disconnect the unit’s main power.
- Always mount this unit in safe and stable matter.
- Power cords should be routed so they are not likely to be walked on, pinched by items placed upon or against them.
- Cleaning -The fixture should be cleaned only as recommended by the manufacturer. See page 23 for cleaning details.
- Heat -The appliance should be situated away from heat sources such as radiators, heat registers, stoves, or other appliances (including amplifiers) that produce heat.
- The fixture should be serviced by qualified service personnel when:
 - A. The power-supply cord or the plug has been damaged.
 - B. Objects have fallen, or liquid has been spilled into the unit.
 - C. The unit has been exposed to rain or water.
 - D. The unit does not appear to operate normally or exhibits a marked change in performance.

NON-INTERLOCKED HOUSING WARNING

The Royal Sky contains high power laser devices internally. **Do not** open the laser housing, due to the potential exposure to unsafe levels of laser radiation. The laser power levels, if the unit is opened, can cause instant blindness, skin burns and fires.

**STOP AND READ ALL LASER SAFETY DATA
OPERATION INSTRUCTIONS AND LASER SAFETY**

The light source emitted from this product can potentially cause eye injury if not set up and used properly. The light source emitted from a laser is very different from any other light sources with which you may be aware of. Laser light is thousands of times more concentrated than any light from any other kind of light source. This concentration of light can cause instant eye injuries, primarily by burning the retina (the back of your eyeball containing cells that are sensitive to light). Even if you cannot feel “heat” from a laser beam, it can still potentially injure or blind you or your audience. Even very small amounts of laser beam light are potentially hazardous even at long distances. Laser eye injuries can be sustained faster than you can blink.

Do not think that because this laser splits the laser beam into hundreds of beams and that the laser beam is scanned out in high speed, that an individual laser beam is safe for eye exposure. This laser uses dozens of milliwatts of laser power (Class 3B levels internally) before it splits into multiple beams (Class 3R levels). Many of the individual beams are potentially hazardous to the eyes. Do not think that because the laser light is moving, it is safe. This is not true. Nor, do the laser beams always move. Since eye injuries can occur instantly, it is critical to prevent even the smallest possibility of any direct eye exposure. In the laser safety regulation, it is not legal to aim Class 3R lasers in areas which people can get exposed. This is true even if it is aimed below people’s faces, such as on a dance floor.

Do not operate the laser without first reading and understanding all safety and technical data in this manual.

Always set up and install all laser effects so that all laser light is at least 3 meters (9.8 feet) above the floor on which people can stand.

- After setting up, and before public use, test laser to ensure proper function. Do not use if any defect is detected. Do not use if laser emits only one or two laser beams rather than dozens/hundreds, as this could indicate damage to the diffraction grating optic, and could allow emission of higher laser levels above Class 3R.
- Do not point lasers at people or animals. Never look into the laser aperture or laser beams.
- Do not point lasers in areas in which people can potentially get exposed, such as uncontrolled balconies, etc.
- Do not point lasers at highly reflective surfaces, such as windows, mirrors and shiny metal. Even laser reflections can be hazardous.
- Never point a laser at aircraft, this is a federal offense.
- Never point un-terminated laser beams into the sky.
- Do not expose the output optic (aperture) to cleaning chemicals.
- Do not use laser if the laser appears to be emitting only one or two beams.
- Do not use the laser if the housing is damaged, the housing is open, or if the optics appear damaged in any way.
- Never open the laser housing. The high laser power levels inside of the protective housing can start fires, burn skin and will cause instant eye injury.
- Never leave this device running unattended.
- The operation of a class 3R laser show is only allowed if the show is controlled by a skilled and well-trained operator, familiar with the data included in this manual.
- The legal requirements for using laser entertainment products vary from country to country. The user is responsible for the legal requirements at the location/country of use.
- Always use proper lighting safety cables when hanging lights and effects overhead.

Power Supply: The ADJ Boom Box FX2 contains an automatic voltage switch, which will auto sense the voltage when it is plugged into the power source. With this switch there is no need to worry about the correct power voltage, this unit can be plugged in anywhere.

DMX-512: DMX is short for Digital Multiplex. This is a universal protocol used by most lighting and controller manufactures as a form of communication between intelligent fixtures and controllers. A DMX controller sends DMX data instructions from the controller to the fixture. DMX data is sent as serial data that travels from fixture to fixture via the DATA “IN” and DATA “OUT” XLR terminals located on all DMX fixtures (most controllers only have a DATA “OUT” terminal).

DMX Linking: DMX is a language allowing all makes and models of different manufactures to be linked together and operate from a single controller, as long as all fixtures and the controller are DMX compliant. To ensure proper DMX data transmission, when using several DMX fixtures try to use the shortest cable path possible. The order in which fixtures are connected in a DMX line does not influence the DMX addressing. For example; a fixture assigned a DMX address of 1 may be placed anywhere in a DMX line, at the beginning, at the end, or anywhere in the middle. When a fixture is assigned a DMX address of 1, the DMX controller knows to send DATA assigned to address 1 to that unit, no matter where it is located in the DMX chain.

Data Cable (DMX Cable) Requirements (For DMX and Primary/Secondary Operation): The Boom Box FX2 can be controlled via DMX-512 protocol. The Boom Box FX2 is has 2 DMX channel modes, a 3 channel mode and 19 channel mode. The DMX address is set electronically using the controls on the back panel of the unit. Your unit and your DMX controller require a approved DMX-512 110 Ohm Data cable for data input and data output (Figure 1). We recommend Accu-Cable DMX cables. If you are making your own cables, be sure to use standard 110-120 Ohm shielded cable (This cable may be purchased at almost all professional sound and lighting stores). Your cables should be made with a male and female XLR connector on either end of the cable. Also remember that DMX cable must be daisy chained and cannot Figure 1 be split.



Figure 1

Notice: Be sure to follow figures two and three when making your own cables. Do not use the ground lug on the XLR connector. Do not connect the cable's shield conductor to the ground lug or allow the shield conductor to come in contact with the XLR's outer casing. Grounding the shield could cause a short circuit and erratic behavior.

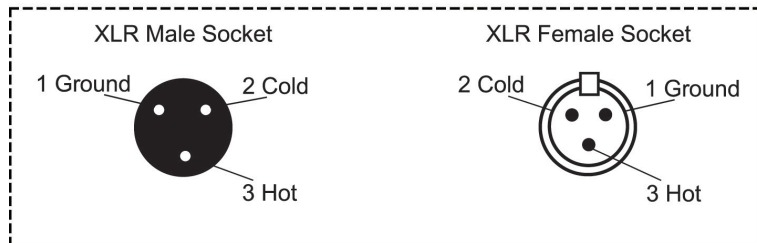

| XLR Pin Configuration |
|------------------------------------|
| Pin 1 = Ground |
| Pin 2 = Data Compliment (negative) |
| Pin 3 = Data True (positive) |

Special Note: Line Termination. When longer runs of cable are used, you may need to use a terminator on the last unit to avoid erratic behavior. A terminator is a 110-120 ohm 1/4 watt resistor which is connected between pins 2 and 3 of a male XLR connector (DATA + and DATA -). This unit is inserted in the female XLR connector of the last unit in your daisy chain to terminate the line. Using a cable terminator (ADJ part number Z-DMX/T) will decrease the possibilities of erratic behavior.

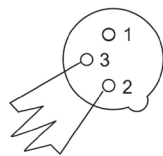

Termination reduces signal errors and avoids signal transmission problems and interference. It is always advisable to connect a DMX terminal, (Resistance 120 Ohm 1/4 W) between PIN 2 (DMX-) and PIN 3 (DMX+) of the last fixture.

5-Pin XLR DMX Connectors. Some manufactures use 5-pin XLR connectors for DATA transmission in place of 3-pin. 5-pin XLR fixtures may be implemented in a 3-pin XLR DMX line. When inserting standard 5-pin XLR connectors in to a 3-pin line a cable adaptor must be used, these adaptors are readily available at most electric stores. The chart below details a proper cable conversion.

| 3-pin XLR to 5-pin XLR Conversion | | |
|------------------------------------------|-------------------------------|----------------------------|
| <i>Conductor</i> | <i>3-pin XLR Female (out)</i> | <i>5-pin XLR Male (In)</i> |
| Ground/Shield | Pin 1 | Pin 1 |
| Data Compliment (- signal) | Pin 2 | Pin 2 |
| Data True (+ signal) | Pin 3 | Pin 3 |
| Not Used | | Pin 4 - Do Not Use |
| Not Use | | Pin 5 - Do Not Use |

The unit should be mounted using a mounting clamp (not provided), affixing it to the mounting bracket that is provided with the unit. Always ensure that the unit is firmly fixed to avoid vibration and slipping while operating. Always ensure that the structure to which you are attaching the unit is secure and is able to support a weight of 10 times the unit's weight. Also, always use a safety cable that can hold 12 times the weight of the unit when installing the fixture.

The equipment must be installed by a professional, and it must be installed in a place where it is out of the reach of people's grasp.

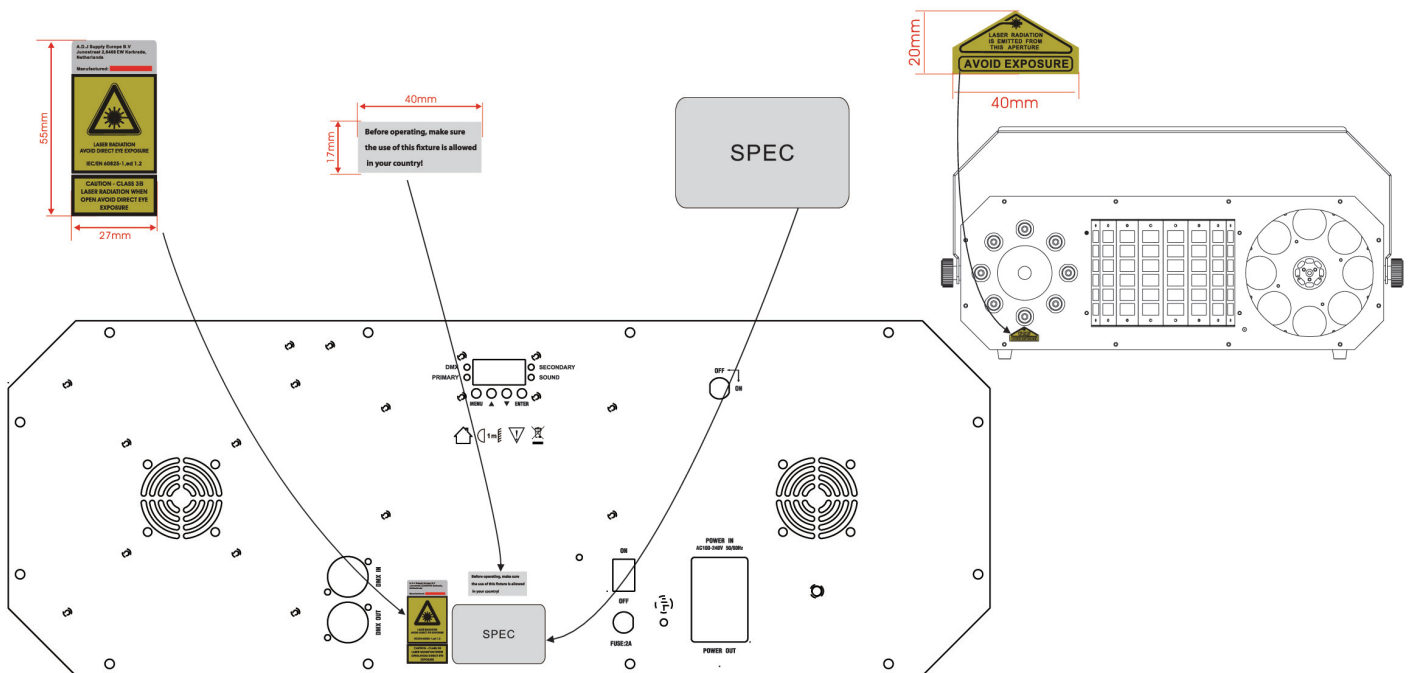
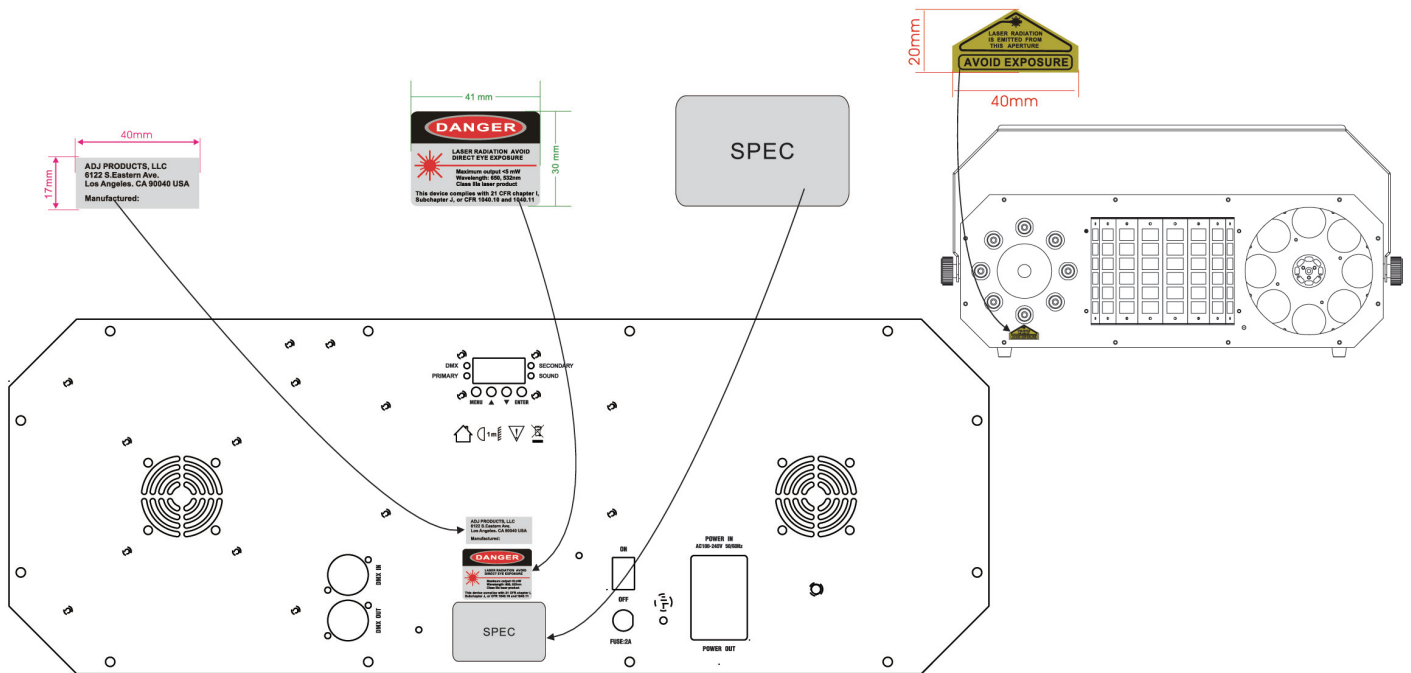

American Version:

EU Version:

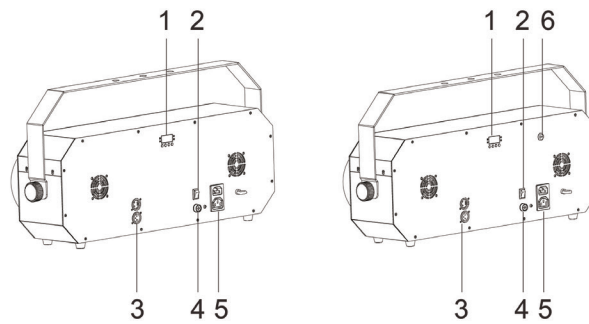

Button:

| | |
|--------------|------------------------------------------|
| MENU | To select the programming functions |
| UP | To go backward in the selected functions |
| DOWN | To go forward in the selected functions |
| ENTER | To confirm the selected functions |

LED:

| | | |
|------------------|----|-------------------|
| PRIMARY | On | Primary mode |
| SECONDARY | On | Secondary mode |
| SOUND | On | Sound activation |
| DMX | On | DMX input present |

1. Function Display: Used to show the various menus and selected functions. (See tables above)
2. On/Off Switch: Used to turn the unit on/off.
3. DMX IN/OUT: For DMX-512 linkage, use a 3-pin XLR cable to connect units together.
4. FUSE (T2A): Protects the unit from damage of over current.
5. POWER IN/OUT: Used to connect to the power outlet or the next fixture.
6. On/Off Key for Laser: Turns the laser on/off. **(Only for EU version)**

Boom Box FX2

Dimensional Drawing

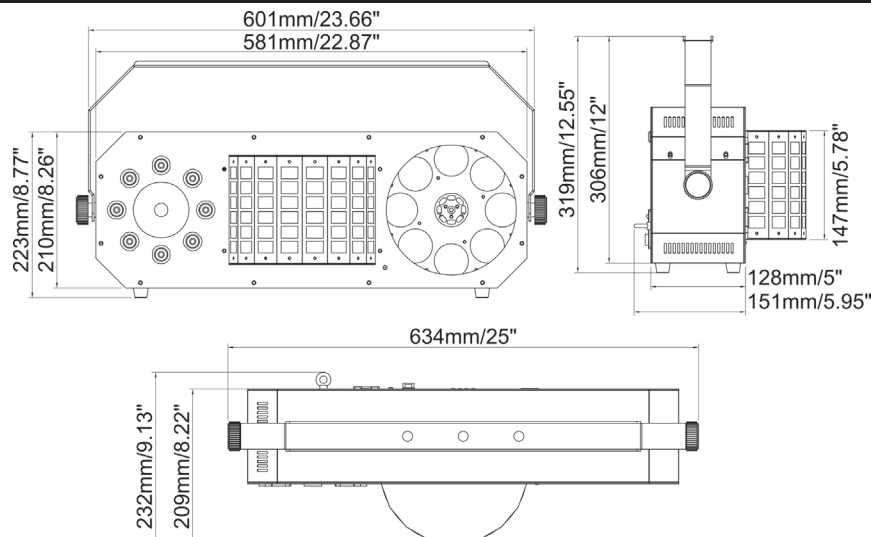

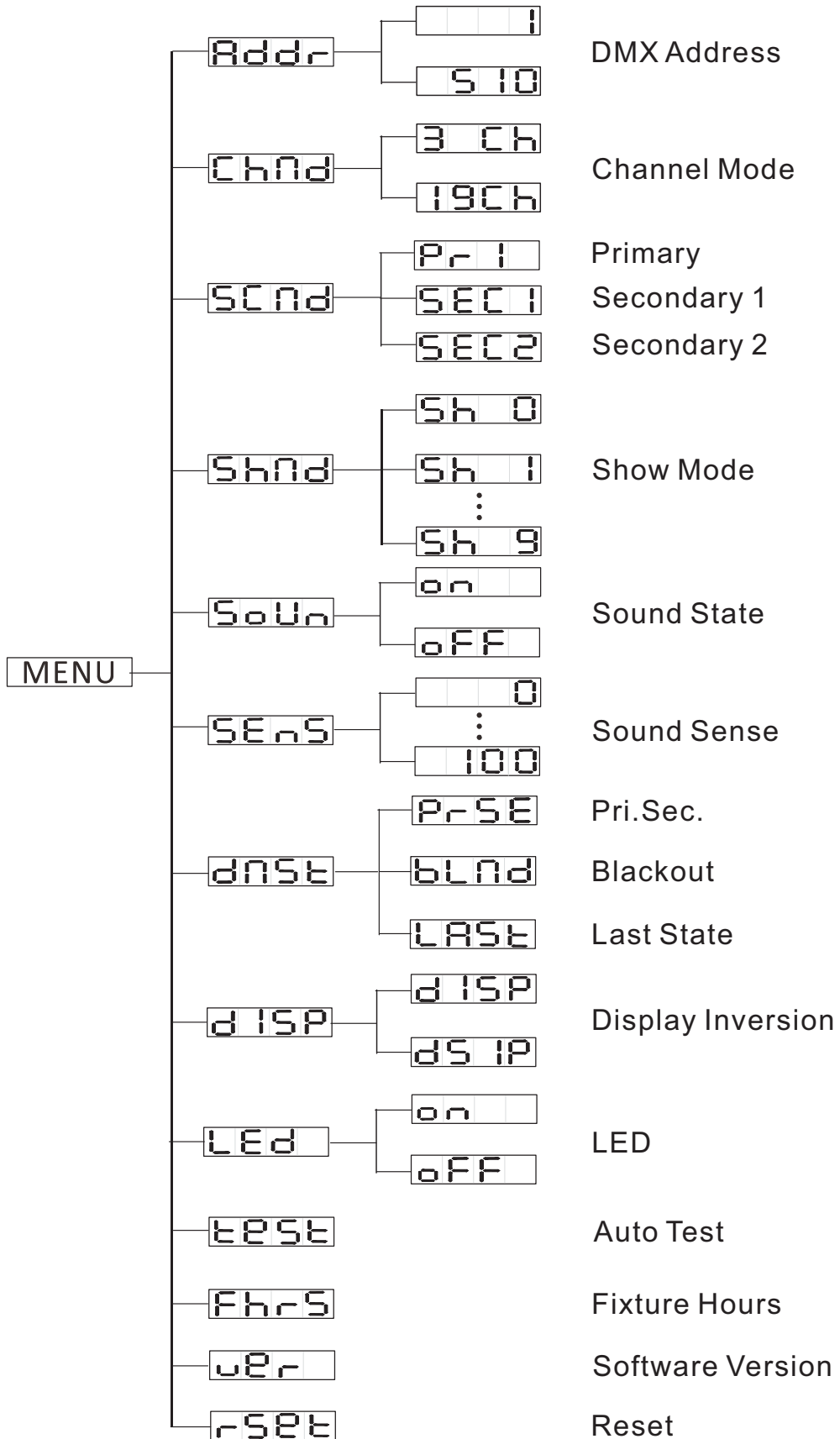

System Menu: When making adjustments press **ENTER** to confirm your setup then press and hold the **MENU** button for at least 3 seconds. To exit without making any adjustments press the **MENU** button. The display will lock after 30 seconds, press the **MENU** button for 3 seconds to unlock.

ADDR - DMX Address Setting.

1. Press the either the MENU, UP, or DOWN buttons until “ADDR” is displayed, press ENTER.
2. The current address will now be displayed and flashing. Press the UP or DOWN buttons to find your desired address. Press ENTER to set your desired DMX address.

CHND - This will let select your desired DMX channel mode.

1. Press the MENU button until “CHND” is displayed, press ENTER. The current DMX channel mode will be displayed.
2. Press the UP or DOWN buttons to find your desired DMX channel mode and press ENTER to confirm and exit.

SCND - This will let you configure your unit in primary mode or secondary mode.

1. Press the MENU button until “SCND” is displayed, press ENTER. Either “Pr1”, “Sec 1”, or “Sec 2” will be displayed.
2. Press the UP or DOWN buttons until your desired setting is displayed, press ENTER to confirm.

NOTE: In a Primary/Secondary configuration you can set one fixture to Primary and then set the next fixture to “Sec 2”, the fixtures will now have contrast movement to each other.

SHND - Show modes 0-9 (Factory programs).

1. Press the MENU button until “SHND” is displayed, press ENTER.
2. “Sh X” will now be displayed, “X” representing a number between 0-6. Shows 1-6 are factory programs, while show “0” is random mode. Use the UP or DOWN buttons to find your desired show.
3. When you have found your desired show press ENTER, then press and hold the MENU button for at least 3 seconds to activate. After you have set your desired show, it can be changed at any time using the UP or DOWN buttons.

SOUN - Sound Active mode.

1. Press the MENU button until “SOUN” is displayed, press ENTER.
2. The display will show either “ON” or “OFF”. Press the UP or DOWN buttons to select “ON” to activate sound active mode, or “OFF” to deactivate sound active mode.
3. Press ENTER to confirm.

SENS - In this mode you can adjust the sound sensitivity.

1. Press the MENU button until “SENS” is displayed, press ENTER.
2. A number between 0-100 will be displayed. Press the UP or DOWN buttons to adjust the sound sensitivity, with 0 being the least sensitive, and 100 being the most sensitive.
3. When you have found your desired setting press ENTER to confirm.

DNST - This mode can be used as a precaution mode, in case the DMX signal is lost, interrupted, or power is lost, the operating mode chosen in the setup is the running mode the fixture will go into when the DMX signal is lost. You can also set this as the operating mode you would like the unit to return to when power is applied.

1. Press the MENU button until “DNST” is displayed, and either “PRSE”, “BLND”, or “LAST” will be displayed beneath.
2. Press ENTER and the bottom choice will begin to flash. Use the UP or DOWN buttons to choose an operating mode you would like the unit to start up in when power is applied or the DMX signal is lost.
 - *LAST* - If the DMX signal is lost the fixture will stay in the last DMX setting. If power is applied and this mode is set, the unit will automatically go into the last DMX set up.
 - *PRSE (Primary/Secondary)* - If the DMX signal is lost or power is applied, the unit will automatically go into Primary/Secondary mode and run a built-in show.
 - *BLAC (Blackout)* - If the DMX signal is lost or interrupted, the unit will automatically go into stand by mode.
3. Press ENTER to confirm your desired set up.

DISP - This function will reverse the display 180°.

1. Press the MENU button until “DISP” is displayed, press ENTER.
2. Press ENTER to “flip” the display.
Press ENTER to “flip” it again. Press ENTER when you have made your desired setup.

LED - With this function you can have the LED display turn off after 10 seconds.

1. Press the MENU button until “LED” is displayed, press ENTER.
2. The display will show either “ON” or “OFF”. Press the UP or DOWN buttons to select “ON” to keep the LED display on at all times, or “OFF” to switch to have the LED display switch off after 10 seconds.

TEST - This function will run a self test program.

1. Press the MENU button until “TEST” is displayed, press ENTER.
2. The fixture will now run a self test.

FHRS - With this function you can display the running time of the unit.

1. Press the MENU button until “FHRS” is displayed, press ENTER.
2. The running time of the fixture will now be displayed. Press MENU to exit.

VER - Use this function to display the Software version of the unit.

1. Press the either the MENU button until “VER” is displayed, press ENTER.
2. The display will show the software version.

RSET - This function will reset the unit.

1. Press the MENU button until “RSET” is displayed. Press the ENTER button and the unit will reset itself.

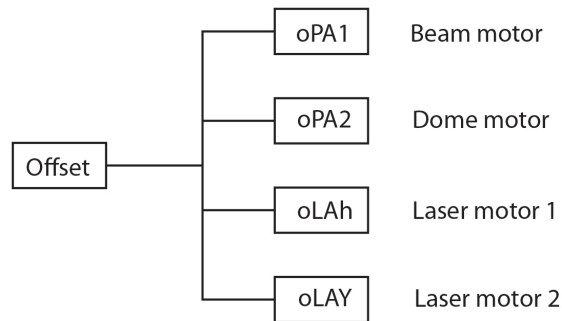

To enter the home position adjustment menu, press the ENTER button for at least 5 seconds. In this submenu you are able to adjust the original position of the beam and gobo motors and laser motors.

oPA1 - Adjustment of the beam motor.

1. Press the ENTER button for at least 5 seconds, then press the UP or DOWN buttons so that “oPA1” is displayed, press ENTER.
2. Use the UP and DOWN buttons to make your adjustments, and then press ENTER to confirm. Press the MENU button for one second to exit.

oPA2 - Adjustment of the gobo motor.

1. Press the ENTER button for at least 5 seconds, then press the UP or DOWN buttons so that “oPA2” is displayed, press ENTER.
2. Use the UP and DOWN buttons to make your adjustments, and then press ENTER to confirm. Press the MENU button for one second to exit.

oLAh - Adjustment of laser motor 1.

1. Press the ENTER button for at least 5 seconds, then press the UP or DOWN buttons so that “oLAh” is displayed, press ENTER.
2. Use the UP and DOWN buttons to make your adjustments, and then press ENTER to confirm. Press the MENU button for one second to exit.

oLAY - Adjustment of laser motor 2.

1. Press the ENTER button for at least 5 seconds, then press the UP or DOWN buttons so that “oLAY” is displayed, press ENTER.
2. Use the UP and DOWN buttons to make your adjustments, and then press ENTER to confirm. Press the MENU button for one second to exit.

Universal DMX Control: This function allows you to use a universal DMX-512 controller to control the patterns, rotation and strobing. A DMX controller allows you to create unique programs tailored to your individual needs.

1. The Boom Box FX2 has a 2 DMX channel modes; a 3 channel mode and 19 channel mode. See pages 21-24 for detailed description of the DMX values and traits.
2. To control your fixture in DMX mode, follow the set-up procedures on pages 7-9 as well as the set-up specifications that are included with your DMX controller.
3. Follow the instructions on page 13 to select your desired DMX channel mode and set the DMX address.
4. For longer cable runs (more than a 100 feet) use a terminator on the last fixture.
5. For help operating in DMX mode consult the manual included with your DMX controller.

Sound Active Mode: This mode allows a single unit or several units linked together, to run to the beat of the music.

1. Press the MENU button until "Soun" is displayed, and press ENTER.
2. Press the UP or DOWN buttons to either activate sound active mode or deactivate, and press ENTER. The unit will now run to the beat of the music.
3. The sound sensitivity can be adjusted by pressing the MENU button until "Sens" is displayed, and then press ENTER. Use the UP or DOWN buttons to adjust the sound sensitivity, 0 being the least sensitive, and 100 being the most sensitive.

Show Mode: This mode allows a single unit or several units linked together, to run 1 of 9 built-in shows.

1. Press the MENU button until "Shnd" is displayed, and press ENTER.
2. Press the UP or DOWN buttons to find your desired show and press ENTER. The unit will now run your chosen built-in program.

Primary-Secondary Operation This function will allow you to link up to 16 units together and operate without a controller. In a Primary-Secondary set up, one unit will act as the controlling unit and the others will react to the controlling units programs. Any unit can act as a Primary or as a Secondary.

1. Using approved DMX data cables, daisy chain your units together via the XLR connector on the rear of the units. Remember the Male XLR connector is the input and the Female XLR connector is the output. The first unit in the chain (primary) will use the female XLR connector only - The last unit in the chain will use the male XLR connector only. For longer cable runs we suggest a terminator at the last fixture.
2. On the Primary unit press the MENU button until “SCND” is displayed, and press ENTER. Use the UP and DOWN buttons to scroll to the “Pr 1” setting and press ENTER.
3. After setting the Primary unit to the primary setting find and set your desired operating mode.
4. On the secondary units press the MENU button until “SCND” is displayed, and press ENTER. Choose either “Sec 1” or “Sec 2” and press ENTER.
5. The secondary units will now follow the primary unit.

With this feature you can connect the fixtures to one another using the IEC input and output sockets. The quantity that can be connected is 9 fixtures maximum @ 120V, and 17 fixtures @ 230V. After the maximum amount of fixtures has been reached, you will need to use a new power outlet. They must be the same fixtures. DO NOT mix fixtures.

The **UC IR (sold separately)** infrared remote gives you control of various functions (See below). To control the fixture you must aim the remote at the front of the fixture and be no more than 30 feet away.

The Boom Box FX2 is also compatible with the **Airstream IR** app. The IR transmitter is available through any ADJ dealer or through the ADJ parts website. Plug the transmitter into the headphone jack of your iOS phone or tablet. To control your IR fixture you must raise the volume to the maximum on your iOS phone or tablet and aim the transmitter at the front of the fixture and be no more than 15 feet away. After you have purchased the Airstream IR transmitters, the app is a free download from the app store for your iOS phone or tablet. The app comes with 3 pages of control depending on the IR fixture you are using. Please see below for IR functions including the corresponding app page.

Works with App page 1.

STAND BY - Pressing this button will blackout the fixture. Press the button again to return to the initial state.

FULL ON - Hold this button down to fully light up the unit. When you let the button go, the unit will return to its previous state.

STROBE - Press and hold this button for strobing.

FADE/GOBO - This button is invalid for this fixture.

“DIMMER +” and “DIMMER -” - These button’s is invalid for this fix-ture.

COLOR - This button is invalid for this fixture.

1-9 - Use buttons 1-9 to select your desired show when show mode is activated.

SOUND ON & OFF - Use the buttons to activate and deactivate sound active mode.

SHOW 0 - Press this button to activate show mode. Use buttons 1-9 to find your desired show.

| Channel | Value | Function |
|------------------|---------------------|-------------------------------|
| 1 | 0 - 69 | SHOW MODE |
| | 70 - 79 | NO FUNCTION |
| | 80 - 89 | SHOW 1 |
| | 90 - 99 | SHOW 2 |
| | 100 - 109 | SHOW 3 |
| | 110 - 119 | SHOW 4 |
| | 120 - 129 | SHOW 5 |
| | 130 - 139 | SHOW 6 |
| | 140 - 209 | SHOW 7 |
| | 210 - 249 | SHOW 8 |
| | 250 - 255 | SHOW 9 |
| 2 | 0 - 255 | SHOW 0 |
| | | SHOW SPEED |
| 3 | 0 - 255 | SHOW SPEED SLOW - FAST |
| | | SPECIAL FUNCTIONS |
| | | NO FUNCTION |
| | | RESET ALL |
| | | NO FUNCTION |
| 250 - 255 | SOUND ACTIVE | |

| Channel | Value | Function |
|----------------|----------------------------------------------------------------------------------------------------------------------------------------------------------------------------------------------|--------------------------------------------------------------------------------------------------------------------------------------------------------------------------------------------------------------------------------------------------|
| 1 | 0 - 9 10 - 255 | CENTER LED EFFECT NO FUNCTION COLOR MACROS |
| 2 | 0 - 127 128 - 255 | RED LASER (CENTER) CLOSED OPEN |
| 3 | 0 - 127 128 - 255 | GREEN LASER (CENTER) CLOSED OPEN |
| 4 | 0 - 255 | LASER PATTERN (CENTER) LASER PATTERNS |
| 5 | 0 - 255 | RED BEAM EFFECT 0% - 100% |
| 6 | 0 - 255 | GREEN BEAM EFFECT 0% - 100% |
| 7 | 0 - 255 | BLUE BEAM EFFECT 0% - 100% |
| 8 | 0 - 255 | WHITE BEAM EFFECT 0% - 100% |
| 9 | 0 - 7 8 - 15 16 - 131 132 - 139 140 - 181 182 - 189 190 - 231 232 - 239 240 - 247 248 - 255 | BEAM EFFECT STROBING CLOSED OPEN STROBING SLOW - FAST OPEN FAST CLOSE - SLOW OPEN OPEN FAST OPEN - SLOW CLOSE OPEN RANDOM STROBE OPEN |
| 10 | 0 - 255 | BEAM EFFECT MASTER DIMMER 0% - 100% |

| Channel | Value | Function |
|---------|------------------------------------------------------------------------------------------------------------------------------------|------------------------------------------------------------------------------------------------------------------------------|
| 11 | 0 - 127 128 - 189 190 - 193 194 - 255 | BEAM EFFECT MOTOR ROTATION MOTOR INDEXING CLOCKWISE ROTATION SLOW - FAST STOP CLOCKWISE ROTATION FAST - SLOW |
| 12 | 0 - 9 10 - 255 | RED GOBO EFFECT CLOSED OPEN |
| 13 | 0 - 9 10 - 255 | GREEN GOBO EFFECT CLOSED OPEN |
| 14 | 0 - 9 10 - 255 | BLUE GOBO EFFECT CLOSED OPEN |
| 15 | 0 - 9 10 - 255 | WHITE GOBO EFFECT CLOSED OPEN |
| 16 | 0 - 127 128 - 189 190 - 193 194 - 255 | GOBO EFFECT MOTOR ROTATION MOTOR INDEXING CLOCKWISE ROTATION SLOW - FAST STOP CLOCKWISE ROTATION FAST - SLOW |
| 17 | 0 - 69 70 - 79 80 - 89 90 - 99 100 - 109 110 - 119 120 - 129 130 - 139 140 - 209 210 - 249 250 - 255 | SHOW MODE NO FUNCTION SHOW 1 SHOW 2 SHOW 3 SHOW 4 SHOW 5 SHOW 6 SHOW 7 SHOW 8 SHOW 9 SHOW 0 |
| 18 | 0 - 255 | SHOW SPEED SLOW - FAST |

| Channel | Value | Function |
|----------------|--------------|-------------------|
| 19 | 0 - 139 | SPECIAL FUNCTIONS |
| | 140 - 209 | NO FUNCTION |
| | 210 - 249 | RESET ALL |
| | 250 - 255 | NO FUNCTION |
| | | SOUND ACTIVE |

Boom Box FX2

Fuse Replacement

Disconnect the unit from its power source. Remove the power cord from the unit. Once the cord has been removed, you will find that the fuse holder is located inside the power socket. Insert a flat-head screw driver into the power socket and gently pry out the fuse holder. Remove the bad fuse and replace with a new one. The fuse holder also has a holder for a spare fuse.

Boom Box FX2

Cleaning

Fixture Cleaning: Due to fog residue, smoke, and dust cleaning the internal and external optical lenses and mirror should be carried out periodically to optimize light output. Cleaning frequency depends on the environment in which the fixture operates (i.e. smoke, fog residue, dust, dew). In heavy club use we recommend cleaning on a monthly basis. Periodic cleaning will ensure longevity, and crisp output.

1. Use normal glass cleaner and a soft cloth to wipe down the outside casing.
2. Use a brush to wipe down the cooling vents and fan grill.
3. Clean the external optics and mirror with glass cleaner and a soft cloth every 20 days.
4. Clean the internal optics with glass cleaner and a soft cloth every 30-60 days.
5. Always be sure to dry all parts completely before plugging the unit back in.

Boom Box FX2

Trouble Shooting

Trouble Shooting: Listed below are a few common problems that you may encounter, with solutions.

No light output from the unit:

1. Be sure the external fuse has not blown. The fuse is located on the rear panel of the unit.
2. Be sure the fuse holder is completely and properly seated.

Unit does not respond to sound:

1. Low frequencies (bass) should cause the unit to react to sound. Tapping on the microphone, quiet or high pitched sounds may not activate the unit.
2. Check the sound sensitivity level.

MANUFACTURER’S LIMITED WARRANTY

- A. ADJ Products, LLC hereby warrants, to the original purchaser, ADJ Products, LLC products to be free of manufacturing defects in material and workmanship for a prescribed period from the date of purchase (see specific warranty period on reverse). This warranty shall be valid only if the product is purchased within the United States of America, including possessions and territories. It is the owner’s responsibility to establish the date and place of purchase by acceptable evidence, at the time service is sought.
- B. For warranty service you must obtain a Return Authorization number (RA#) before sending back the product—please contact ADJ Products, LLC Service Department at 800-322-6337. Send the product only to the ADJ Products, LLC factory. All shipping charges must be pre-paid. If the requested repairs or service (including parts replacement) are within the terms of this warranty, ADJ Products, LLC will pay return shipping charges only to a designated point within the United States. If the entire instrument is sent, it must be shipped in it’s original package. No accessories should be shipped with the product. If any accessories are shipped with the product, ADJ Products, LLC shall have no liability whatsoever for loss of or damage to any such accessories, nor for the safe return thereof.
- C. This warranty is void if the serial number has been altered or removed; if the product is modified in any manner which ADJ Products, LLC concludes, after inspection, affects the reliability of the product; if the product has been repaired or serviced by anyone other than the ADJ Products, LLC factory unless prior written authorization was issued to purchaser by ADJ Products, LLC; if the product is damaged because not properly maintained as set forth in the instruction manual.
- D. This is not a service contract, and this warranty does not include maintenance, cleaning or periodic check up. During the period specified above, ADJ Products, LLC will replace defective parts at its expense with new or refurbished parts, and will absorb all expenses for warranty service and repair labor by reason of defects in material or workmanship. The sole responsibility of ADJ Products, LLC under this warranty shall be limited to the repair of the product, or replacement thereof, including parts, at the sole discretion of ADJ Products, LLC. All products covered by this warranty were manufactured after August 15, 2012, and bear identifying marks to that effect.
- E. ADJ Products, LLC reserves the right to make changes in design and/or improvements upon its products without any obligation to include these changes in any products theretofore manufactured.

No warranty, whether expressed or implied, is given or made with respect to any accessory supplied with products described above. Except to the extent prohibited by applicable law, all implied warranties made by ADJ Products, LLC in connection with this product, including warranties of merchantability or fitness, are limited in duration to the warranty period set forth above. And no warranties, whether expressed or implied, including warranties of merchantability or fitness, shall apply to this product after said period has expired. The consumer’s and/or Dealer’s sole remedy shall be such repair or replacement as is expressly provided above; and under no circumstances shall ADJ Products, LLC be liable for any loss or damage, direct or consequential, arising out of the use of, or inability to use, this product.

This warranty is the only written warranty applicable to ADJ Products, LLC Products and supersedes all prior warranties and written descriptions of warranty terms and conditions heretofore published.

MANUFACTURER’S LIMITED WARRANTY PERIODS:

- Non L.E.D. Lighting Products = 1-year (365 days) Limited Warranty (Such as: Special Effect Lighting, Intelligent Lighting, UV lighting, Strobes, Fog Machines, Bubble Machines, Mirror Balls, Par Cans, Trussing, Lighting Stands etc. excluding LED and lamps)
- Laser Products = 1 Year (365 Days) Limited Warranty (excluding laser diodes which have a 6 month limited warranty)
- L.E.D. Products = 2-year (730 days) Limited Warranty (excluding batteries which have a 180 day limited warranty). Note: 2 Year Warranty only applies to purchases within the United States.
- StarTec Series = 1 Year Limited Warranty (excluding batteries which have a 180 day limited warranty).
- ADJ DMX Controllers = 2 Year (730 Days) Limited Warranty

| | |
|--------------------------------|---------------------------------------------------------------------------------------------------------------------|
| Model: | Boom Box FX2 |
| Voltage: | 100V ~ 240V 50/60 Hz |
| LED: | 8 x 3W (2 Red, 2 Green, 2 Blue, 2 White) LEDs 8 x 1W (2 Red, 2 Green, 2 Blue, 2 Amber) LEDs 8 x 10W RGBW LEDs |
| Laser: | Red & Green Laser Diodes |
| Power Draw: | 62W |
| Fuse: | 2A |
| Power Cord Daisy Chain: | 9 Fixtures Max (120V) 17 Fixtures Max (230V) |
| Dimensions: | 9" (L) x 25" (W) x 12.5" (H) 232 x 634 x 319mm |
| Weight: | 17 lbs / 8 kgs |
| Duty Cycle: | None |
| DMX Channels: | 2 DMX Modes: 3 & 19 Channels |
| Sound Active: | Yes |
| Working Position: | Any Safe, Secure Position |
| Warranty: | 1 Year (365 Days) |

Auto Sensing Voltage: *This fixture contains an automatic voltage switch, which will automatically sense the voltage when it is plugged into the power source.*

Please Note: *Specifications and improvements in the design of this unit and this manual are subject to change without any prior written notice.*

ADJ Products, LLC
6122 S. Eastern Ave, Los Angeles, CA, 90040 USA
Tel: 323-582-2650 / Fax: 323-725-6100
Web: www.adj.com / E-mail: info@adj.com

ADJ Supply Europe B.V.
Junostraat 2
6468 EW Kerkrade
The Netherlands
service@adj.eu / www.adj.eu

Follow Us On:



facebook.com/americanadj
twitter.com/americanadj
youtube.com/adjlighting

Tel: +31 45 546 85 00 / Fax: +31 45 546 85 99

